

GURLEY MODEL 9710 VIRTUAL ABSOLUTE ENCODER

MOTION TYPE:

ROTARY OR LINEAR

USAGE GRADE:

PROTECTED INDUSTRIAL

OUTPUT:

ABSOLUTE

*MAX RESOLUTION:

2^{22} STEPS/REV. (~0.3 ARCS)

0.25 M

*W/EXTERNAL ELECTRONICS



- ABSOLUTE OUTPUT
- MANY DISC SIZES

- FRICTION FREE OPERATION
- VACUUM-COMPATIBLE OPTION

The Model **9710** is a versatile read head that can be configured for use with either a rotary disc or linear scale. Its modular construction provides friction-free operation, and the wide selection of disc sizes gives the design engineer great flexibility

When used with the **Model VA** or other interpolating decoder, its optical resolution is electronically increased. The natural-binary position output is augmented by a number of built-in test functions for maximum system reliability.

For incremental positioning in a modular encoder, please refer to the **9710 (rotary)**, **7700 (rotary and linear in a compact package)**, and **9717 (linear only)** datasheets

ingenuity@work

ISO
9001
CERTIFIED

Gurley Precision Instruments
514 Fulton Street
Troy, NY 12180 U.S.A.
(800) 759-1844, (518) 272-6300, fax (518) 274-0336,
Online at www.gurley.com, e-mail: info@gurley.com



SPECIFICATIONS

Electrical	
Input Power	V_{CC} : +5VDC 0.25 VDC@ 10 mA I_{LED} : +20mA regulated DC current source
Light Source	Screened infra-red LED; rated life > 100,000 hours
Output Signals	High-output differential Sine, Cosine, and Index photocurrents. Signal levels are designed for proper operation with GPI's various electronics packages. Consult factory to establish criteria for waveforms when 9710 is used with other electronics.
Mechanical	
Materials Encoder Body Scale of Disk	Aluminum Vacuum-deposited chrome pattern on glass
Weight Read Head Scale	1.7 oz (49g) + cable @ 0.034 oz/in (0.04 g/mm) 0.31 oz/in (0.34 g/mm) (1.125" x 0.189" cross-section)
Performance	
Frequency Response	50 kHz, all channels (Max. Speed may be limited by subsequent electronics; see data sheet for Model VA interpolating decoder.)
Quadrature Error	$\pm 30^\circ$ typical (depends on user's installation)
Scale Accuracy Standard Optional	± 0.0001 in/ft (8 m/m) ± 0.00005 in/ft (4 m/m)
Disc Accuracy Dia 3" Dia 3"	± 10 arcs ± 5 arcs
Environmental	
Operating Temp. Humidity Shock Vibration	-40 F to +185 F (40 C to +85 C) 98% rh, non-condensing 50g, 11 ms 2g, 0-2000 Hz

As part of our continuing product improvement program, all specifications are subject to change without notice.



THEORY OF OPERATION - SHORT VERSION

Virtual Absolute (VA) discs and scales are similar to incremental discs and scales in that they contain a cyclic track and an index track. In an incremental encoder, the index occurs at one place in the full travel, but in a VA encoder, the index track is a continuous serial code (similar in appearance to a bar code). You don't know position immediately upon start-up, as you do in a conventional absolute, but after a very short travel, *in either direction and starting from anywhere*, you know exactly where you are. In a rotary VA, this *initialization* angle is typically about one degree, depending on the encoder's line count; in a linear VA encoder, less than 1 mm motion is needed. From then on, the encoder is truly absolute. (There are ways to build a pseudorandom encoder so that absolute information is available on power-up without initializing, but these techniques require far more complex sensing hardware; they often impose slower operation as well. And none of them offers the sophisticated built-in testing of GPI's *Virtual Absolute* technology.)

To complete the system, the **9710** is used with one of Gurley's **Interpolating Decoders**. The size of a credit card, it contains patented high-speed circuitry to decode the special serial index track and interpolation to increase the final resolution. In addition to the natural binary position output, a *Status* bit is provided to tell you when the encoder is initialized. This bit is at a logic high whenever the initializing motion is not yet complete, or when some other problem such as supply voltage interruption, electrical noise, damage, or fouling of the disc interferes with the proper code sequence from the index track. When these self-tests are all satisfied, the status bit is low, indicating the position data output is valid. The **9710** is usually used with the **Model VA** interpolating decoder, but other versions are added from time to time.

For a more thorough discussion, refer to the data sheet for the **Model VA**.

DISCS

Gurley does not offer disc hubs as catalog items, but we will mount discs to customer-furnished hubs, and we can provide hubs designed for your specific application. Even if we are not providing the mounting or the hub, we strongly suggest that you consult with us regarding the proper design of the disc/hub assembly and mounting of the **9710** Read Head. All dimensions are in inches (mm). Consult factory for other sizes or line counts (including non-binary numbers).

O.D.	I.D.	Thick	#Lines ⁽¹⁾	Init. angle	Throat	CL-Mntg	P/N
3.13 (79.502)	1.45 (36.830)	0.125 (3.175)	4096 R	1.05°	0.105 (2.667)	1.918 (48.717)	CX01327
4.30 (109.220)	2.78 (70.612)	0.100 (2.540)	4096 R	1.05°	0.100 (2.540)	2.500 (63.500)	CX01115
4.80 (121.920)	2.90 (73.630)	0.120 (3.048)	4096 R	1.05°	0.105 (2.667)	2.755 (69.977)	CX01071
6.40 (162.560)	4.40 (111.760)	0.125 (3.175)	4096 R	1.05°	0.106 (2.692)	3.556 (90.322)	CX01258
9.00 (228.600)	6.00 (152.400)	0.250 (6.350)	16384 R ⁽²⁾	0.31°	0.062 (1.575)	4.812 (122.225)	CX01296
16.25 (412.750)	14.00 (355.600)	0.235 (5.969)	4096 S	1.05°	n/a	6.650 (168.910)	CX01346
19.50 (495.300)	15.50 (393.700)	0.010 (.0254)	2048 R	1.94°	0.105 (2.667)	9.480 (240.792)	BX02049

- (1) **R** means read head straddles disc O.D.; this is the preferred method.
S means read head straddles disc I.D.; consult factory.

- (2) This disc requires an interpolating decoder other than the **Model VA**; consult factory.



SCALES

The following scales are available from existing masters. Additional standard scales may be added periodically; we can always make special scales on a custom basis.

Scale pitch	Maximum resolution *	Max. measuring length	Cross-section	Initialization distance
64 μm	0.25 μm	262.144 mm (10.32")	1.125" x 0.125" (28.575 x 3.175 mm)	768 μm (0.030")

* with **Model VA** support electronics

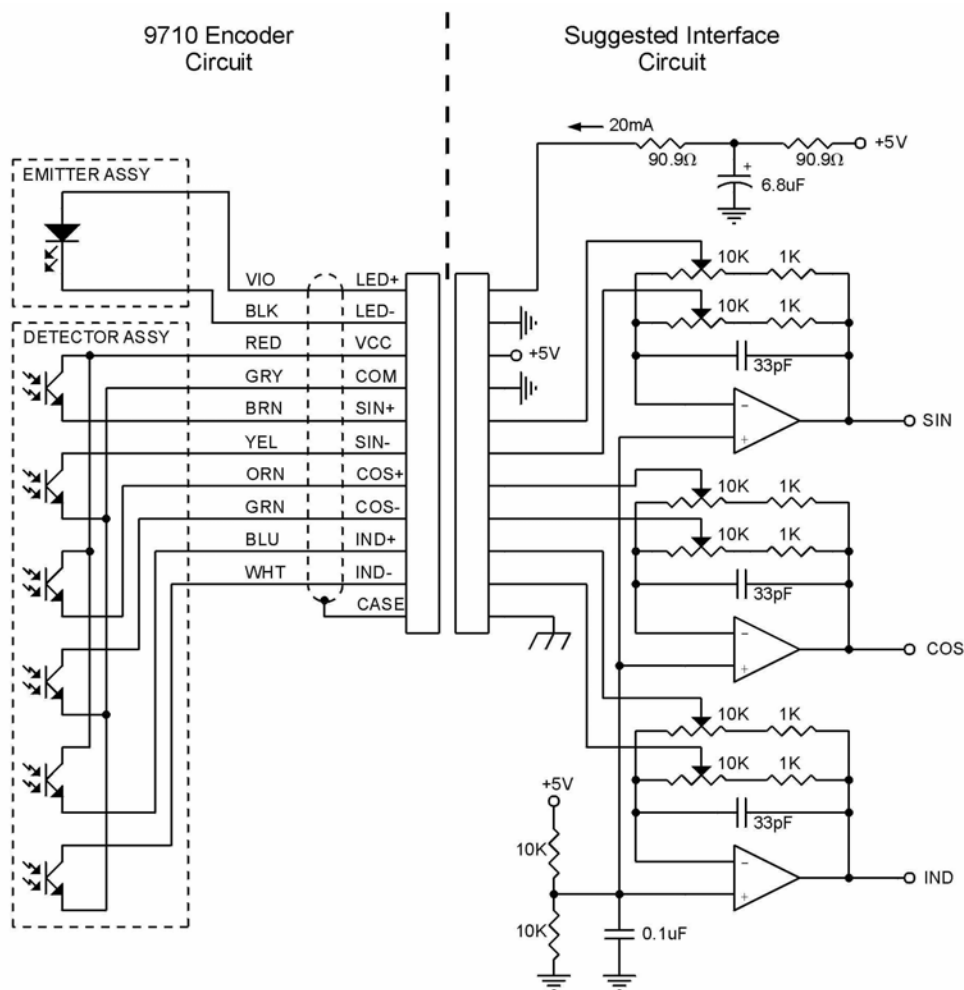

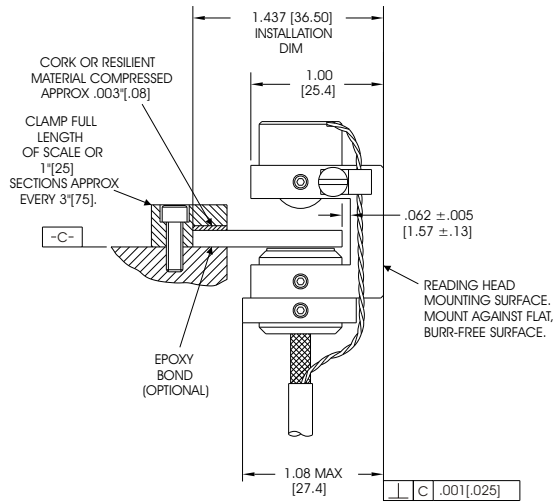
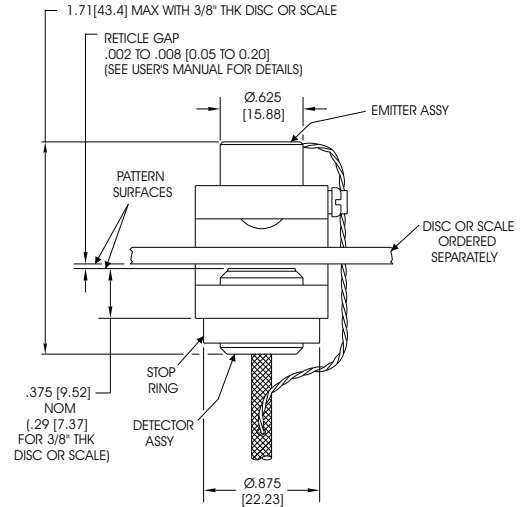
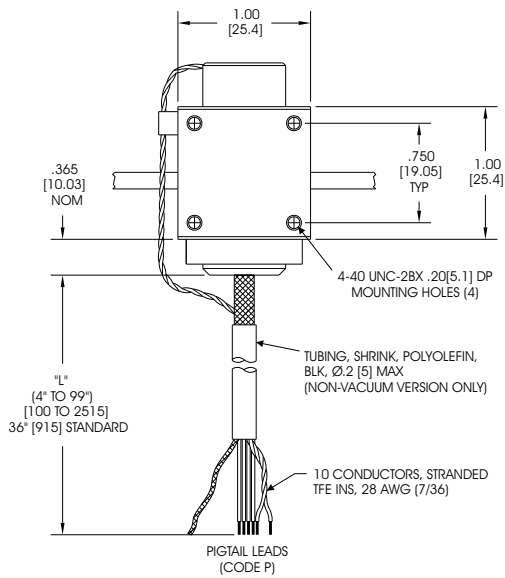

LINEAR APPLICATIONS

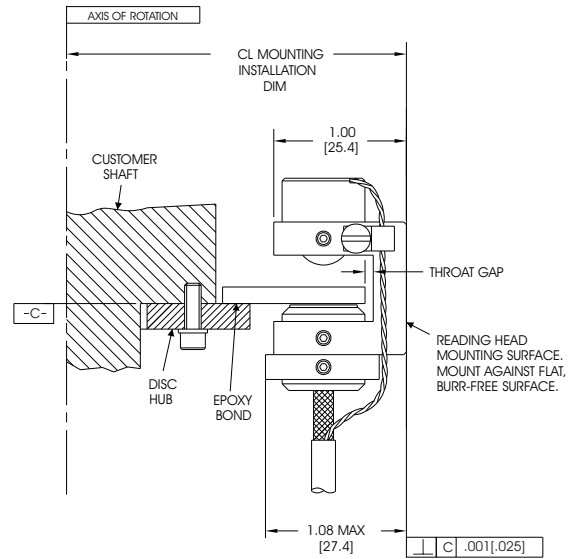

ROTARY APPLICATIONS

SUGGESTED MOUNTING METHODS

ORDERING INFORMATION

	ENV	LINES	TYPE	IND	LENGTH	CONN	DIA	SF
9710	<input style="width: 40px; height: 30px; border: 1px solid black;" type="text"/>	<input style="width: 40px; height: 30px; border: 1px solid black;" type="text"/>	<input style="width: 40px; height: 30px; border: 1px solid black;" type="text"/>	<input style="width: 40px; height: 30px; border: 1px solid black;" type="text"/>	<input style="width: 40px; height: 30px; border: 1px solid black;" type="text"/>	<input style="width: 40px; height: 30px; border: 1px solid black;" type="text"/>	<input style="width: 40px; height: 30px; border: 1px solid black;" type="text"/>	<input style="width: 40px; height: 30px; border: 1px solid black;" type="text"/>

<u>ENV</u>	S V	Standard environment Vacuum-compatible
<u>LINES</u>	#####	Lines/rev (if <u>TYPE</u> = R or S), scale pitch in μin (if <u>TYPE</u> = E), or scale pitch in μm (<u>TYPE</u> = M). Add leading zeroes for 5 digits total.
<u>TYPE</u>	R S M E	Rotary with head straddling the O.D. Rotary with head on the I.D. (consult factory) Metric scale (<u>LINES</u> = $\mu\text{m}/\text{line}$) English scale (<u>LINES</u> = $\mu\text{in}/\text{line}$)
<u>INDEX</u>	S	Single aperture
<u>LNPTH</u>	## 36	Cable length in inches (04-99) Standard
<u>CONN</u>	P R V	Pigtails (no connector) DE-15P (use with CAZxxx extension cable from 9710 to VA electronics) Amp 102387-1 (to connect 9710 directly to VA electronics)
<u>DIA</u>	#### 9999	Disc O.D. (if <u>TYPE</u> = R), or disc I.D. (if <u>TYPE</u> = S). Diameter in inches, to the nearest 0.01", with no decimal point; example: 0390 = 3.90". Add leading zero for 4 digits total. Use for linear encoders (<u>TYPE</u> = E or M)
<u>SF</u>	# N	Issued at time of order to cover special customer requirements No special features

Specify disc or scale separately

Options and accessories

- VA** *Virtual Absolute* Interpolating Decoder. See **Model VA** data sheet
- CAZxxx** Extension cable xxx inches long; **9710** to **Model VA**

SPECIAL CAPABILITIES

For special situations, we can optimize encoders to provide higher frequency response, greater accuracy, wider temperature range, reduced torque, non-standard line counts, or other modified characteristics. In addition, we regularly design and manufacture custom encoders for user-specific requirements. These range from high-volume, low-cost, limited-performance commercial applications to encoders for high-performance, high-reliability conditions. We welcome the opportunity to help you with your special encoder needs.

WARRANTY

Gurley Precision Instruments offers a limited warranty against defects in material and workmanship for a period of one year from the date of shipment.

